

DOCUMENT RESUME

ED 213 849

CE 031 472

TITLE Agribusiness Safety. Module SH-15. Safety and Health.

INSTITUTION Center for Occupational Research and Development, Inc., Waco, Tex.

SPONS AGENCY Office of Vocational and Adult Education (ED). Washington, DC. Div. of National Vocational Programs.

PUB DATE 81

CONTRACT 300-79-0709

NOTE 42p.; For related documents see CE 031 450-507.

AVAILABLE FROM The Center for Occupational Research and Development, 601 Lake Air Dr., Suite C, Waco, TX 76710 (Instructor Guides, \$9.75 each; Learning Modules, \$3.00 each. Entire set of Learning Modules available as two subsets: SH-21, SH-41, SH-43, SH-45, and SH-48, \$12.00; remaining 45 modules, \$97.50).

EDRS PRICE MF01 Plus Postage. PC Not Available from EDRS.

DESCRIPTORS \*Agribusiness; Behavioral Objectives; Electricity; Emergency Programs; Equipment Utilization; Fire Protection; \*Health Education; \*Learning Activities; Learning Modules; Pesticides; Postsecondary Education; Safety; \*Safety Education; Secondary Education; Structural Elements (Construction); \*Vocational Education; Waste Disposal

IDENTIFIERS \*Occupational Safety and Health

ABSTRACT

This student module on agribusiness safety is one of 50 modules concerned with job safety and health. Following the introduction, 11 objectives (each keyed to a page in the text) the student is expected to accomplish are listed (e.g., List at least two reasons for agribusiness safety standards). Then each objective is taught in detail, sometimes accompanied by illustrations. Learning activities are included. A list of references and answers to learning activities complete the module. (CT)

\*\*\*\*\*  
 \* Reproductions supplied by EDRS are the best that can be made \*  
 \* from the original document. \*  
 \*\*\*\*\*

# SAFETY AND HEALTH

ED213849

CE031472

AGRIBUSINESS SAFETY

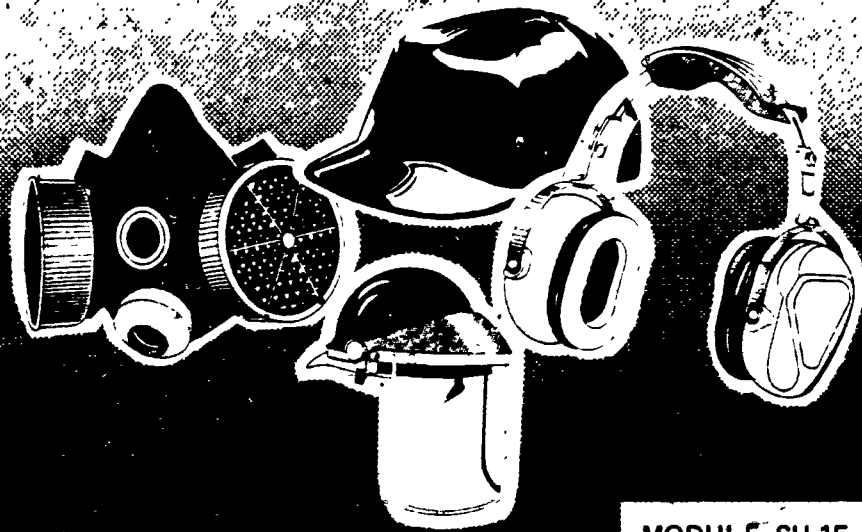

MODULE SH-15

U.S. DEPARTMENT OF EDUCATION  
NATIONAL INSTITUTE OF EDUCATION  
EDUCATIONAL RESOURCES INFORMATION  
CENTER (ERIC)

This document has been reproduced  
exactly as received from the person or  
organization that provided it.  
Minor changes have been made to  
improve readability.

Permission to reproduce this  
material in microfiche only  
has been granted by

PERMISSION TO REPRODUCE THIS  
MATERIAL IN MICROFICHE ONLY  
HAS BEEN GRANTED BY

D. Hull

TO THE EDUCATIONAL RESOURCES  
INFORMATION CENTER (ERIC)

**ORD**

CENTER FOR OCCUPATIONAL RESEARCH AND DEVELOPMENT

**DISCRIMINATION PROHIBITED** — No person in the United States shall, on the ground of race, color, or national origin, be excluded from participation in, be denied the benefits of, or be subjected to discrimination under any program or activity receiving Federal financial assistance, or be so treated on the basis of sex under most education programs or activities receiving Federal assistance.

The activity which is the subject of this document was supported in whole or in part by the U. S. Department of Education. However, the opinions expressed herein do not necessarily reflect the position or policy of the Department of Education, and no official endorsement by the Department of Education should be inferred.

This work was developed under contract number 300790709 for the U. S. Department of Education, Office of Vocational and Adult Education.



The U. S. Department of Education and the Center for Occupational Research and Development assume no liability for personal injury or property damage incurred by any person or organization making use of the material contained herein. Use of the materials herein is for educational and training purposes and is not to be considered as an exemption from either Federal or State Regulations, and is to be considered as advisory only.

All rights reserved. No part of this work covered by the copyrights hereon may be reproduced or copied in any form or by any means — graphic, electronic, or mechanical, including photocopying, recording, taping, or information and retrieval systems — without the express permission of the Center for Occupational Research and Development.

COPYRIGHT © 1981

The Center for Occupational Research and Development  
601 Lake Air Drive, Suite C  
Waco, Texas 76710

## INTRODUCTION

Growing, processing, and distributing food, fiber, and forest products combine to form one of the most important commercial enterprises in the United States today. While the labor force involved in the production of agricultural goods has declined steadily over the last half century, the per capita production of each worker has risen sharply. This increased productivity can be attributed primarily to mechanization of farm work and to technological changes in pest control, fertilization, and crop improvement through controlled breeding.

Much of the world outside of the United States has come to depend upon U.S. agriculture for survival. Our own country depends heavily upon agricultural trade to balance economic exchange between the U.S. and other nations. The standard of living that citizens of the U.S. enjoy relies on abundant agricultural production. To meet their production goals, farm operators must have the help and support of related businesses. These businesses include such diverse groups as chemical and fertilizer manufacturers, farm equipment builders and distributors, research groups involved in genetic research, and even bankers and financial institutions.

With so many persons engaged in the vital business of agriculture, safety becomes a very important consideration.

According to the Bureau of Labor Statistics<sup>1</sup> there was about one job-related injury or illness for every 11 workers in the private economy during 1979. There were also about 4950 work-related deaths in workplaces with 11 or more employees. Considering the number of workers in agriculture, this means that almost 100,000 agricultural workers suffered lost work days due to illness or injury during 1979. There was also an increase from 95 to 110 work related deaths. Figures such as these support the study of agriculture and agribusiness safety.

<sup>1</sup>"News-United States Department of Labor," Office of Information, Washington, D.C., USDL 80-726 and 727, November 20, 1980.

## OBJECTIVES

Upon completion of this module, the student should be able to:

1. Define agribusiness in a short paragraph. (Page 3)
2. List at least two reasons for agribusiness safety standards. (Page 4)
3. Describe the procedure for electrical wire inspection, preventing overloads, and techniques for proper grounding. (Page 5)
4. Discuss the use of extinguishers, the effect of trash disposal, and storage of flammable and combustible materials for fire prevention. (Page 8)
5. Briefly summarize labeling, handling, storage, and disposal problems and precautions associated with agricultural pesticides. (Page 10)
6. Cite the reason for and basic design of lightning protection devices. (Page 17)
7. Describe three approaches that may be used to control or eliminate pest population. (Page 20)
8. Summarize the electrical safety, noise abatement, exhaust procedures, and machine guards related to farm industry installed machinery. (Page 22)
9. Discuss the workplace use of fire extinguishers, automatic sprinklers, and alarm systems for fire protection. (Page 28)
10. Describe in a few sentences the proper storage, labeling, safe use, and security for hazardous materials. (Page 31)
11. Describe the safety guidelines for housekeeping, walking and working surfaces, exits, and disaster plans. (Page 34)

## SUBJECT MATTER

**OBJECTIVE 1:** Define agribusiness in a short paragraph.

The contemporary term "agribusiness" is the result of combining the words agriculture and business. Its use is an indication of the complex and highly sophisticated nature of agriculture in the last quarter of the twentieth century. In an earlier and perhaps less complicated era, when farming was primarily a family operation and when most of the products used in the production of crops came from the farm itself, there was no need for the concept represented by this term. During this previous time, even distribution was farm-based. However, the changes in the production and distribution of agricultural commodities have given rise to a need for the complex system known as agribusiness.

Agribusiness includes those businesses that support the production activities of the farmer. The manufacturing and distribution of farm equipment and supplies, and the processing, distribution, and storage of farm commodities are some of the more common agribusinesses. These businesses employ skilled and unskilled laborers, trained technicians, and professionals with college training and degrees in a wide range of activities related to supplying food, fiber, and forest products.

### ACTIVITY 1:

Briefly define agribusiness, including a sentence or two explaining why this term has come into use.

---

---

---

---

\*Answers to Activities begin on page 36.

**OBJECTIVE 2:** List at least two reasons for establishing agribusiness safety standards.

Wherever people work with chemicals, machinery, and animals, there exists danger that accidents will occur. Since workers with varying degrees of training are employed in a wide range of activities in agribusiness, safety training is a must if safe work habits are to be developed.

On-the-job accidents caused by careless workers, and illness caused by unhealthy work conditions continue to exact their toll in pain, disability, and death. While the effective treatment of many diseases and injuries has improved greatly over the years, prevention is still the far better course. Awareness of potential hazards on the job can reduce the likelihood of injury to workers, and positive attitudes toward safe practices can do more to reduce accident in the workplace than any regulation imposed by any governmental agency.

The suffering alone would be reason enough to encourage safety education and the imposition of safety standards. But there is another element involved. The economic loss associated with occupational injury and disease was approximately 23 billion dollars in 1978.<sup>2</sup> Such losses cost each worker \$240.00 in lost wages, insurance, and medical charges. These figures were based on 80 work days lost per 100 workers in 1978. In 1979, 83 work days per 100 workers were lost by agriculture workers, and with the spiralling cost of insurance and medical treatment each worker undoubtedly suffered greater financial loss.

**ACTIVITY 2:**

Describe briefly the two most important reasons for agribusiness's safety standards.

---

---

---

---

<sup>2</sup>"Accident Facts," National Safety Council, 444 N. Michigan Avenue, Chicago, Ill. 60611, 1979 edition.

**OBJECTIVE 3:** Describe the procedure for electrical wire inspection, preventing overloads, and techniques for proper grounding.

Agricultural safety can be divided into two areas: that related to on-the-farm activities and that pertaining to off-the-farm agricultural businesses.

Electrical safety, a key on the farm item, is the responsibility of owner, manager, and workers. Most farming operations occur outside the jurisdiction of municipality controls which means that city building, electrical and plumbing codes do not have to be met. It is quite possible that persons doing electrical work on farms will lack the qualifications of those who, because they work in a city, are required to demonstrate skill to obtain a license to practice their trade. Any farming operation with 11 or more employees, however, is subject to OSHA inspection; therefore, electrical and other safety standards should be observed.

Inspection, proper installation, and safe operation of electrical devices depend upon the attitude and skill of the people who work with them each day. Routine inspection of electrical wiring requires that the worker have knowledge of safe practices. The worker should be aware of and watch for the potential dangers represented by overloaded circuits, improperly grounded machinery, damaged or frayed electric cords and plugs, wet areas around electrical equipment, and outlets and switches not properly covered.

Overloaded circuits can easily occur and go unnoticed unless the overload causes a fuse or circuit breaker to trip. There are two main dangers: fire and damage to motors attached to the overloaded circuit. Fire can occur when the current demands of the machinery attached to a line are greater than the current-carrying capacity of the circuit. The overloaded line then produces heat in the circuit that is transferred to surrounding materials perhaps eventually causing them to burn. To prevent overloading, the current-carrying ability of the conductor (wire) and the current requirements of all devices connected to the circuit must be known. Current is measured in amperes (amps). On the plate attached to most machines will be a statement of minimum electrical requirements. These must be stated in amps and volts,



or they may be given in watts. The current-carrying ability of the conductor or circuit will be indicated by the size fuse or circuit breaker that is in the line. If the breaker or fuse is labeled "15 amps," then the combination of lights, motors, etc., attached to that circuit should require no more than a total of 15 amps. If the current required is not expressed, but the power needed is given in watts, then the current can be determined by dividing the number of watts by the voltage in the circuit. For example, a small motor requires 600 watts of power to operate when it is attached to a 120 volt circuit. In this case, 5 amps of current would be needed for proper operation.

$$(600 \text{ W} \div 120 \text{ V} = 5 \text{ A})$$

The most common form of circuit overloading occurs when "three-way plugs" and multiple extension cords are used. These invite the user to plug more devices into a circuit than it was designed to carry; therefore, they should be avoided in any home or agribusiness situation. An even greater danger exists when a resistance heating device, such as a dryer, hot plate, laminating device, or iron, is in use. These units require very large amounts of power. When such equipment is in use, it is a good idea to hold the back of the hand near the plug and wires periodically to detect any heat buildup that might be occurring. If the wires, plugs, or switches become hot, the power should be shut off immediately, and the appliance should be disconnected from the circuit as soon as it is cool enough to handle. Such overheating should be reported to the responsible party.

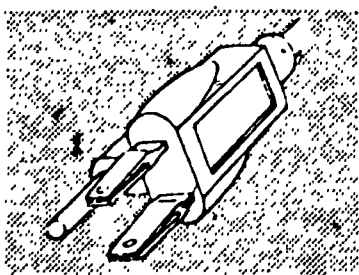

Figure 1. The third prong on an electric cord is there to provide a grounding lead.

Adequate grounding of all devices is an essential means of providing a safe path by which "stray" electricity can reach the ground without causing harm. The third prong of an electric plug (Figure 1) is there to provide a grounding lead. For it to be effective, it must contact a conductor that has been installed in the outlet to provide a continuous, low resistance pathway by which electric current can reach the earth. Most newly installed electrical

outlets are designed to receive three prong plugs. Older style outlets and many new extension cords are not equipped to receive three pronged plugs. One effective way to make an older outlet useable by equipment with three pronged plugs is to put an adapter in the outlet that has a wire coming from it that should be attached to the outlet by the screw holding the cover plate.

The practice of cutting or breaking the third prong off as a matter of convenience is a dangerous act that can cause injury and damage property. In addition to the third prong ground wire that is part of the power cord, any exposed metal part of an electrically powered machine, such as its case or housing, that could be contacted by a person should be grounded separately. Separate grounding wires or straps should be located away from the operator and should be checked periodically to be certain that all connections are tight. Even machinery requiring high voltage or amps can be electrically safe when it is properly installed and maintained.

Ideally, extension cords will be used only rarely and on a temporary basis. When they must be used, there are several safety considerations. The cords themselves should be free of kinks, mashed places, breaks in the insulation, and loose end fittings or plugs. They should be as short as possible, since some electrical force is lost in a longer wire. Flexible cords should never be strung across walkways and should not be allowed to lie in wet or extremely hot places. If flexible cord must be run along the floor, it should be covered only with an approved insulating material. Any such installation must be considered temporary and must be inspected frequently.

**ACTIVITY 3:**

1. An employee who performs routine electrical inspections of a workplace should be alert for five hazards:

- a. \_\_\_\_\_
- b. \_\_\_\_\_
- c. \_\_\_\_\_
- d. \_\_\_\_\_
- e. \_\_\_\_\_

2. One way in which equipment may be grounded is:  
\_\_\_\_\_
3. The following devices (can, cannot) be operated safely on a 240-volt, 30-amp circuit, a 300-watt light bulb, a 3600-watt grain dryer, a 7.5-amp cooler, and a 1-amp radio. \_\_\_\_\_

**OBJECTIVE 4:** Discuss the use of extinguishers, the effect of trash disposal, and the storage of flammable and combustible materials in fire prevention.

The overloaded circuits that have been discussed are one source of the heat that can cause fires in homes, factories, farms, and businesses. As has been explained, these hazards can be eliminated. Other causes of fire damage are also largely preventable. Extinguishers, trash disposal, and material storage can play a part.

While fire extinguishers do not prevent fires, they can keep small fires from growing into major ones when they are readily available and properly used. Certain types of extinguishers are designed for use with certain types of fires. It is important to ensure the proper type of extinguisher is available to control the kind of fire that might occur in each. Extinguishers should always be available wherever machinery is operated and flammables are stored or used. Even the smallest family farming operation will have several work locations (including within the home) where extinguishers should be at hand and where all workers should be trained to use them appropriately.

One of the most important actions that can be taken to prevent fire in any work location is to keep each area clean and free of trash and accumulated rubbish. Good housekeeping will remove many potential causes of fires and many of the materials on which sparks and small fires feed and grow. Dust collections pose a particular problem around the storage area for grain and livestock feeds. Some finely divided grain dust particles are extremely explosive. Other easily burned and, therefore, dangerous materials likely to be found at the site of many farming operations include some fertilizers and

pesticides, vehicle fuel, paint, and solvents. Safe storage for such substances requires that they be kept in closed metal cans or tanks in a suitably ventilated area. These materials should be kept away from heat sources, and smoking should not be permitted in or near the storage area. Each place where potentially hazardous substances are stored should be marked with clear warning and "NO SMOKING" signs. Large quantities of highly flammable materials should not be stored routinely on the farm unless they are stored in permanently installed, underground tanks. Other combustible materials that may pose a danger from fire include wood and lumber stacked in or near buildings, oil and grease, and dried crops such as hay. Next to careless smoking, outdoor burning of trash is among the leading sources of destructive fires in rural areas. (See Figure 2.) Open fires should never be left unattended and

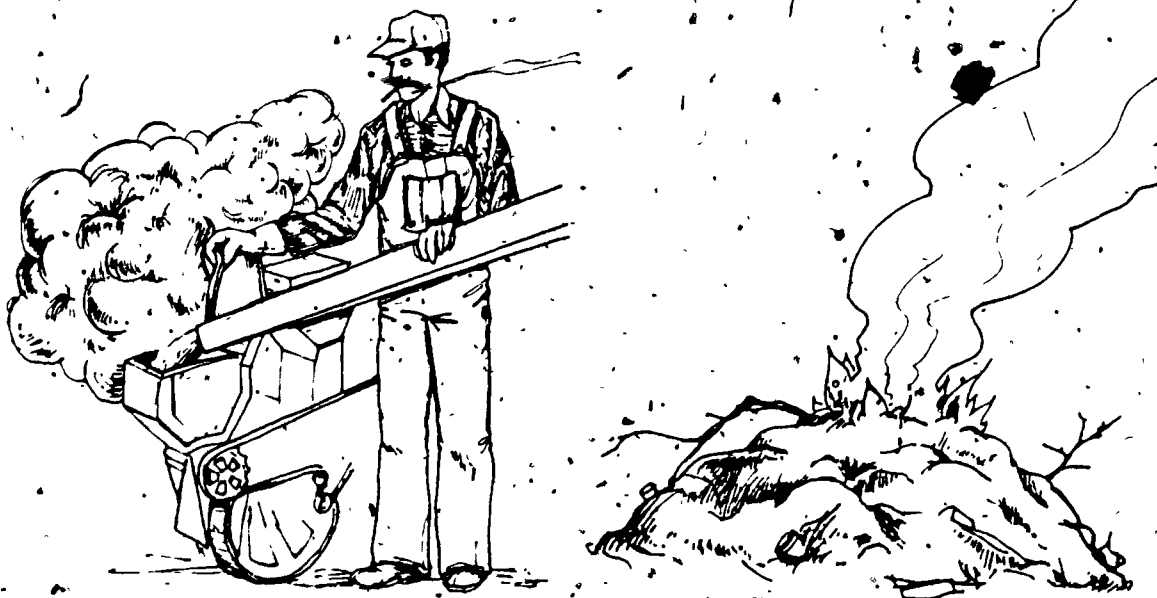

Figure 2. Smoking and outdoor burning of trash are the two leading causes of destructive fires in rural areas.

should not be started when there is a wind. If it is necessary to burn trash, an area around the fire site should be cleared of all material that might burn and a source of water should be available. Keep all fires from structures and be prepared to seek assistance if the fire gets out of hand.

**ACTIVITY 4:**

List three nonelectrical sources of damaging fires on a farm, and describe at least one way that each can be prevented or controlled.

1. \_\_\_\_\_  
\_\_\_\_\_
2. \_\_\_\_\_  
\_\_\_\_\_
3. \_\_\_\_\_  
\_\_\_\_\_

**OBJECTIVE 5:** Briefly summarize labeling, handling, storage and disposal problems; and precautions associated with agricultural pesticides.

Agricultural pesticides have been developed to kill one or more types of organism. These chemicals are usually packaged in concentrated form and many are deadly to humans. Only the uninformed or foolish handle, store, or dispose of pesticides carelessly.

Before any pesticide is used, first determine exactly what the pest is and decide the best way to eliminate it. If chemical treatment is needed, the type of pesticide most appropriate for the treatment must be selected. Local Agricultural Extension Agents, Vocational Agriculture teachers, or pest control operators may be of assistance during these decision making phases.

Once the pesticide has been selected, determine the method of application, the extent of the area to be treated, and the proper amount of chemical for that area. One rule of safety at this point is to buy only the amount of concentrate needed for the application. This avoids problems of safe storage for unused pesticides. All commercially prepared pesticides should have an information label attached to them.

**READ ALL LABELS AND DIRECTIONS FIRST!**

This point cannot be overemphasized. The manufacturer will include safety information as well as chemical specifications directly on the label. One

should read the label before buying, and before using and again before storing any unused portion. A typical label should include most of the information noted on the sample label in Figure 3.

**PRECAUTIONARY STATEMENTS**

**HAZARDS TO HUMANS (DANGER)**

Persons may be suffocated or irritated. Do not breathe spray mist. Do not get in eyes. Avoid contact with skin. Use only when wearing the following protective equipment and clothing: Wear tight-fitting, long-sleeved, long-panted, hooded, and waterproof hat, gloves, boots, and goggles. Wear a respirator if necessary. Approved by the Mining, Enforcement, and Safety Administration and by the National Institute for Occupational Safety and Health. Before removing gloves, wash them with detergent and water. Always wash hands, face, and arms with detergent and water before smoking, eating, or drinking. For emergency assistance, call 000-000-0000.

**TO PHYSICIAN:** De Pesto is a reversible cholinesterase inhibitor. Do not use oximes such as 2-PAM, Gve, Atropine, 2 mg intravenously or subcutaneously. It is an eye irritant and a skin irritant. Close supervision of the patient is indicated for at least 48 hours.

**ENVIRONMENTAL HAZARDS**

This pesticide is toxic to wildlife and fish. Use with care when applying in areas frequented by wildlife or adjacent to any body of water. Keep out of lakes, streams, or ponds. Do not apply where runoff is likely to occur. Do not apply when weather conditions favor drift from target area. Do not contaminate water by cleaning of equipment or disposal of wastes.

**PHYSICAL OR CHEMICAL HAZARDS**

Flammable. Keep away from heat and open flame.

**DIRECTIONS FOR USE**

It is a violation of Federal law to use this product in a manner inconsistent with its labeling.

**RE ENTRY STATEMENT (IF APPLICABLE)**

Do not enter area within 5 days after application.

**CATEGORY OF APPLICATOR (IF APPLICABLE)**

**STORAGE AND DISPOSAL**

**STORAGE:** Do not contaminate water, food, or feed by storage or disposal. Open dumping is prohibited. **DISPOSAL:** Pesticide spray mixture or residue that cannot be used or chemically reprocessed should be disposed of in a landfill approved for pesticides or buried in a safe place away from water supplies. Containers should be triple rinsed and offered for recycling, reconditioning, or disposal in approved landfill or buried in a safe place. Consult Federal State or local Official authorities for approved alternate procedures.

**RESTRICTED USE PESTICIDE**

FOR RETAIL SALE TO AND APPLICATION ONLY BY  
CERTIFIED APPLICATORS OR PERSONS UNDER THEIR  
DIRECT SUPERVISION

DE PESTO

**INSECTICIDE  
EMULSIFIABLE CONCENTRATE**

ACTIVE INGREDIENT† pestoff-tri-salicylic acid	45.0%
INERT INGREDIENTS	55.0%
<b>TOTAL</b>	<b>100.0%</b>

THIS PRODUCT CONTAINS 4.0 LBS OF PESTOFF PER GALLON

**KEEP OUT OF REACH OF CHILDREN  
DANGER — POISON**

**STATEMENT OF PRACTICAL TREATMENT**

**IF SWALLOWED:** Induce vomiting by giving a tablespoonful of salt in a glass of warm water. Repeat until vomiting is clear. Call a physician immediately.

**IF INHALED:** Remove to fresh air. Call a physician immediately.

**IF IN EYES:** Flush eyes with plenty of water for at least 15 minutes. Call a physician immediately.

**IF ON SKIN:** In case of contact, remove contaminated clothing and immediately wash skin with detergent and water.

**SEE SIDE PANEL FOR ADDITIONAL  
PRECAUTIONARY STATEMENTS**

**MFG BY A Z CHEMICALS  
TOWN STATE**

**EPA EST. NO. 1367—STATE—1  
EPA REGISTRATION NO. 1367-42**

NET CONTENTS ONE GALLON

**DIRECTIONS FOR USE  
CONTINUED**

**METHODS OF APPLICATION:** The minimum gateage requirement is 10 gallons of finished spray per acre with ground equipment; 2 gallons per acre with aircraft.

**ALFALFA:** Air and Ground Application—Alfalfa Weevil Larvae, Egyptian Alfalfa Weevil Larvae, Rag Aphid, and in New York states for Shear Beetle control. Apply the amount of De Pesto indicated in the chart when feeding is noticed or when insects appear. Alfalfa Weevil Adult—Apply 1.2 pints per acre when insects appear. Lygus Bugs—Apply 2 pints per acre prior to bloom. Observe the indicated number of days after application before cutting or grazing. Do not apply more than once per season. Apply only to fields planted to pure stands of alfalfa.

Pints of De Pesto Per Acre	Do Not Cut or Graze Within
1	7 days
2	14 days
3	28 days

**CORN FIELD:** Ground Application—Corn Rootworms—Use 1 1/2 pints of De Pesto per 10,000 linear feet (1 acre with 40 inch spacing). Apply at planting, at a 7 inch band over the row or insect on each side of the row by mixing with water or liquid fertilizers. When De Pesto is used with liquid fertilizers, mix in the following way: making sure that the mixture is physically compatible. Premix 1 part of De Pesto with 2 parts of water. Add the premix to the tank of fertilizer along with rinsings from the premixing container. Maintain agitation in the tank after mixing and during application. Do not mix until ready to use.

**SUGARCANE:** Sugarcane Borer—Apply 1 1/2 pints De Pesto per acre using ground or aerial equipment. Check sugarcane fields weekly beginning in early June and continuing through August. Make first application only after visible joints form and 5% or more of the plants are infested with young larvae feeding in or under the leaf sheath and which have not bored into the stalks. Repeat whenever field checks indicate the infestation exceeds 5%. Do not apply within 17 days of harvest. Do not use in Hawaii.

**ORANGES, LEMONS, GRAPEFRUIT and TANGELOS:** in Arizona and California. Air and Ground Application—Citrus thrips—Apply De Pesto at 1/2 to 1 lb per acre. Use sufficient water to obtain thorough coverage (15 to 18 gal/acre by air). Use the higher rate on severe infestations of thrips. Apply in the early spring before bloom when the new growth is about 2 to 4 inches long. Make additional applications as needed until the new fruit is walnut size. Application at post fall may be critical to prevent fruit scarring. Applications during mid-summer to protect new growth on young trees are also recommended.

Do not apply within 1 day of harvest. Do not graze livestock in treated orchards for 10 days after treatment.

**POTATO:** Tubermom, cabbage looper, aphid, and in areas east of the Mississippi River: leafhoppers and flea beetles. Apply De Pesto at indicated rates when field checks indicate the insect infestation is above 5%. Tubermom, cabbage looper and aphid—apply 1/2 to 1 lb per acre. Leafhopper and flea beetles—apply 1 lb per acre. Do not apply within 14 days of harvest.

Figure 3. A sample label for pesticides.

Pesticide labels are valuable sources of information for the worker; however, they serve several other purposes including:

1. For the manufacturer, the label is a license to sell.
2. For governmental agencies, it is a way to control distribution, storage, use, and disposal of the product.
3. For the user, it is the main source of facts about the proper and legal use of the product.
4. For everyone concerned, the label states special safety measures to be followed.

For anyone handling a pesticide, personal protective devices are a must. Recommended equipment includes items such as those illustrated in Figure 4.

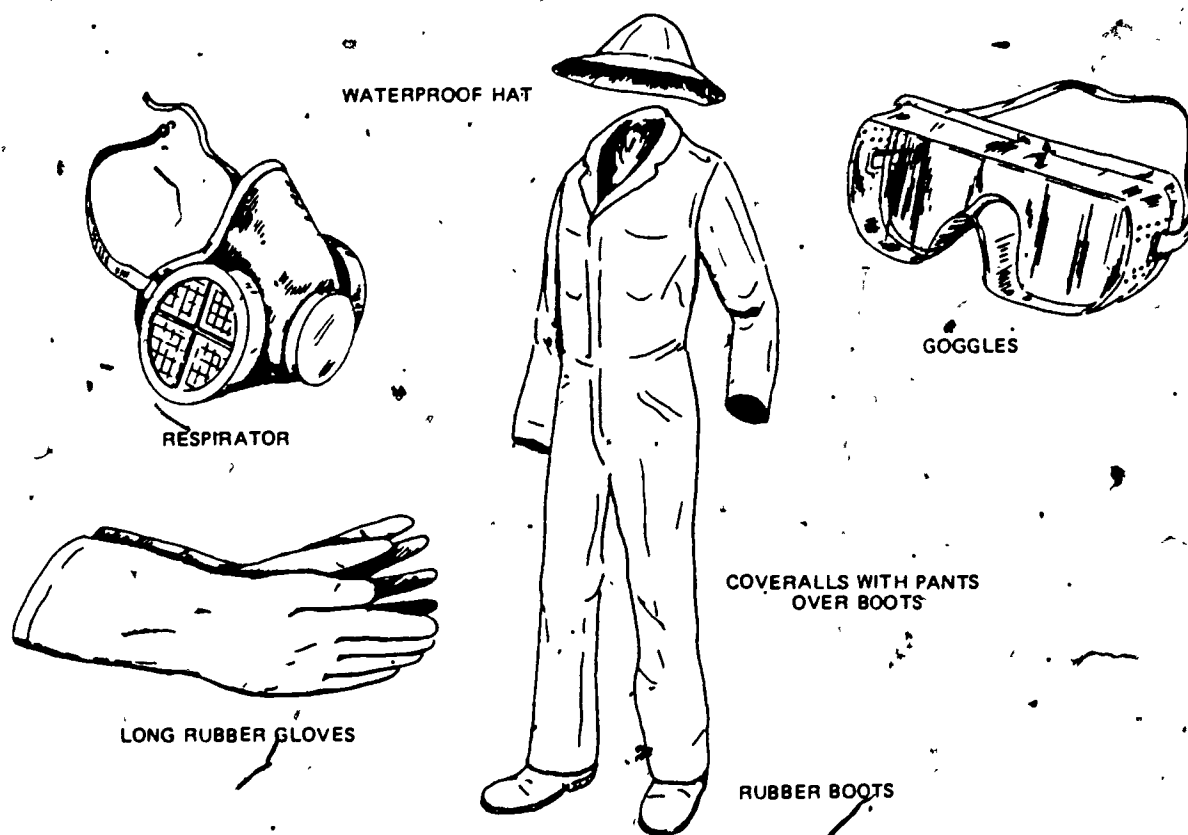

Figure 4. Personal protective devices.

Mixing pesticides should be done out of doors if possible. Prescribed protective clothing as shown in Figure 5 should be worn. If the operation must be carried out in an enclosed area, proper ventilation is essential. The amount to be mixed should not be greater than the approved capacity of the





Figure 5. Protective clothing should be worn by persons mixing pesticides.

container. Livestock, pets, and people who do not need to be present should be kept away from the mixing area. Each time that a pesticide is mixed, directions should be read completely. The operator should not rely on memory, particularly since the instructions for mixing differ for the various chemicals. Sealed paper containers should not be torn open. Rather, the paper container should be cut with a knife and then immediately cleaned.

When mixing or transferring a liquid pesticide, the worker should keep the product below eye level to minimize the chance of splashing it into the face. If a splash or spill occurs during mixing or loading, the process should be stopped at once while workers remove contaminated clothing, wash thoroughly with detergent and water, and clean up the spill. Speed is essential! If there is a breeze in the mixing area, the worker should not stand downwind, instead stand so that the breeze blows away from your body to avoid contamination from blowing dust or mist.

Leaks and spills must be cleaned up promptly. The first concern is to keep people away from the spill. The area should be roped off and flagged and should not be left unattended while danger exists. Every effort should be made to confine the spill to a small area by the use of earthen dikes. If the spill is small, the worker may be able to accomplish the clean-up operation without help. Clean-up consists of (1) absorbing the pesticide with dirt or



sawdust, (2) shoveling the contaminated material into a leakproof container, and (3) disposing of it in an approved manner, that is, according to EPA (Environmental Protection Agency) regulations. After the spilled chemical has been removed, the area SHOULD NOT be hosed down, since this spreads any remaining chemical. The area where the spill occurred should be treated with a substance that will stop the chemical action. Commonly, lye, ammonia, or chlorine bleach are sometimes indicated on the product label for this purpose.

If the spill is a large one, outside help may be needed to clean it up. That help can be obtained by placing a toll-free call to The National Agricultural Chemicals Association Pesticide Safety Team Network. The number is (800) 424-9300. This organization can provide instructions for the correct procedure and referral to the appropriate local agency. In addition, if a major spill occurs along a state highway, the highway patrol or highway department should be notified. If food or water is contaminated by the spill, local and state health officials should be notified.

If a leaking container is discovered before a significant spill has occurred, it should be disposed of in the approved manner. Extreme care should be exercised in handling a leaking container, since the container might rupture and spill its entire contents.

A simple safety technique that should always be followed is known as the "buddy system." This means that an individual never uses hazardous chemicals alone. Workers should form a team with at least two members, so that if one encounters a problem the other will be there to help.

#### PERSONAL CONTAMINATION

If a person becomes contaminated externally, the area of the body affected should be flushed with a large quantity of water. If the contamination is internal (through swallowing, inhaling, or a break in the skin) check the label on the container for proper emergency procedures. In either case, a physician should be consulted at once and provided the exact chemical make up of the pesticide.

It is particularly important to be aware of some of the initial symptoms of pesticide poisoning that might appear when unknown contamination has

occurred. The symptoms may vary depending on the type of pesticide and the level of exposure; however, general symptoms might be:

- Slight exposure - irritation of the skin, eyes, nose and throat; headache, weakness, nausea, diarrhea and dizziness.
- Moderate exposure - blurred vision, difficult breathing, poor muscle coordination, rapid pulse, flushed skin, constriction of pupils of eye, stomach cramps, vomiting and muscle twitches.
- Heavy exposure - convulsions, inability to breathe, loss of consciousness, secretions from mouth and nose, and possibly fever.

The following first aid procedures (given in Table 1) are recommended, but getting medical attention as soon as possible is critical.

TABLE 1. FIRST AID FOR PESTICIDES POISONING.

Contamination	First Aid Procedures
In eyes	Flush with low pressure water for at least 15 minutes.
On skin	Remove clothing, wash with detergent and plenty of water.
Swallowed	Check label - induce vomiting where prescribed.
Inhaled	Get fresh air, lie down, loosen clothing, keep warm and quiet.

One way to reduce the chances of contamination exposure is to use the proper and the safest equipment for the job. Tanks, valves, mixing devices and nozzles should be clean and correctly adjusted before they are put into use. Hoses should be inspected for signs of breakdown and cuts that could permit leaks. Equipment should not be overloaded, as this can lead to spills and to improper mixing or distribution. Training in the use of equipment is usually available from dealers or manufacturer's representatives and is a part of formal training courses offered by schools and the Extension Service. Reading about and understanding the correct use for each piece of equipment using the labels and booklets that come with the products are extremely important to their safe and efficient operations.

Good housekeeping practices can reduce many problems associated with agricultural chemical use. The key words are clean, dry, and well ventilated. Both the mixing and the storage areas should be maintained so as to be clean, dry, and well ventilated at all times. Empty containers should not be reused, but must be properly stored while awaiting disposal. All equipment used in the application of chemicals should be cleaned thoroughly before being put away even for a short time. The water used to wash equipment should be collected for disposal if there is likelihood of a substantial residue of poison.

Disposal of excess pesticides and of pesticide containers should be carried out according to EPA recommendations. If possible, these should be burned in a specially designed pesticide incinerator. If proper facilities for burning are not available, pesticide and containers should be buried in a specially designated landfill. If burning or burial is not possible, the material must be stored until such a time as it can be disposed of in one of these two approved methods.

**ACTIVITY 5:**

1. List six different types of information that will be found on the label of a Restricted Use Pesticide.
  - a. \_\_\_\_\_
  - b. \_\_\_\_\_
  - c. \_\_\_\_\_
  - d. \_\_\_\_\_
  - e. \_\_\_\_\_
  - f. \_\_\_\_\_
2. Three key words or phrases to remember concerning safe storage of pesticides and other farm chemicals are: \_\_\_\_\_, \_\_\_\_\_, and \_\_\_\_\_.
3. If a concentrated pesticide contacts the skin what is the first thing that should be done? \_\_\_\_\_

**OBJECTIVE 6:** Cite the reason for and basic design of lightning protection devices.

Safe practices can control many hazards that might endanger the life or health of workers. There are some dangers, however, that are beyond man's control. When these are considered, safety may depend upon AVOIDING the danger rather than controlling it.

Lightning is the first form of electricity that was observed and recorded by humans. It has been regarded with fear and awe by many and with wonder and curiosity by some. Almost everyone has heard some version of the story about Benjamin Franklin and his kite, and few people today would attempt to fly a kite in an electrical storm. However, when a person is unaware of the conditions under which lightning may be dangerous that person may do something that is almost as risky as was Franklin's kite flying.

Lightning occurs when an atmospheric electric charge moves from one cloud to another or from a cloud to the earth. The charges build up in clouds most often when there is violent movement within the cloud, a condition that occurs during the weather disturbances that are called thunderstorms. In these storms, the differences in density and temperature within the air mass produce the sudden, swift air currents. Lightning, like all other electricity, travels most readily through a conductor. Air is a very poor conductor of electricity. In order for electricity to pass through the air there must be a large buildup of charge or "pressure." When this pressure becomes great enough to move the charge, a violent discharge occurs. Single strokes of lightning have been known to have a pressure of several million volts. It is this terrific quantity of uncontrolled electrical energy that makes lightning so dangerous.

Avoiding lightning requires that a person know where the greatest danger exists. Whenever a person is the highest thing in a large open area, that person becomes the shortest route to the ground for any electrical charge that builds up in the area. On a farm, becoming the path for lightning might occur when a person is riding on or working with machinery in an open field. When there is an electrical storm, avoid the following:

- Contact with metal fences or utility lines.
- The area under or near the base of tall trees, utility poles, and silos.
- Bodies of water such as stock tanks and ponds.

If you are working in a field and get the sensation that the hair on your arms is "standing on end," this is a warning that the ground upon which you are standing and the surrounding air are highly energized. When such a sensation occurs, drop to the ground in a position with knees drawn up under your body, face down and hands placed behind your head and neck with fingers, laced as shown in Figure 6. Taking this position offers the greatest protection in an exposed area and should be maintained until the danger has passed.



Figure 6. A person working in a field who gets the sensation of hair "standing on end" should realize that lightning may strike. The safe action to take is to drop to the ground immediately.

Isolated buildings are vulnerable to the damaging effects of lightning, and many farm fires in such structures are attributed to lightning. A building may be protected from this potential danger by the use of correctly installed lightning arrestors, sometimes called "rods." These devices are simply well designed pathways (conductors) by which the electric charge can reach the ground without causing damage. They usually consist of a pointed

metal rod located at the highest point of the building's roof and connected by well-insulated wire of adequate gage (size) to a large conductor that is buried in the earth. It is important to know that an improperly installed arrester system will do more harm than good, for it may "attract" the charge but be unable to carry it to ground safely. In the illustration below (Figure 7) there are three pointed rods on top of the barn to which the charge

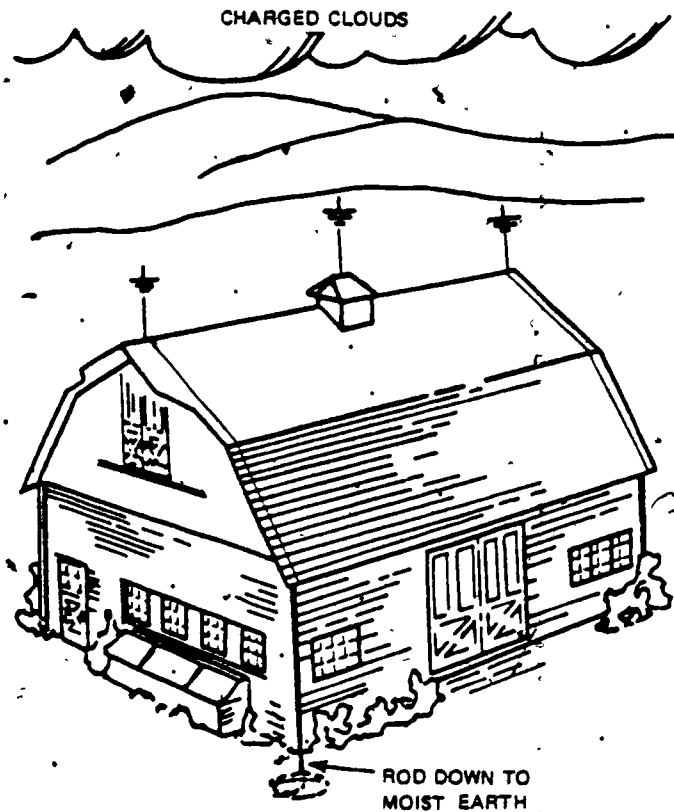

Figure 7. Three lightning rods connected to two different grounds.

may be attracted. These are connected to more than one ground, illustrated here by coiled wire. The buried conductor may be straight, coiled, or in any configuration so long as it is in moist soil.

**ACTIVITY 6:**

1. Name three danger spots to be avoided when there is an electrical storm.
  - a. \_\_\_\_\_
  - b. \_\_\_\_\_
  - c. \_\_\_\_\_
2. To be effective a lightning protection system for a building must be able to \_\_\_\_\_  
\_\_\_\_\_

**OBJECTIVE 7:** Describe three approaches that may be used to control or eliminate pest populations.

Certain agribusiness operations vulnerable to insect and rodent infestations because of their characteristic operations. The control of insects in food processing operations demands that floors, walls, and ceilings of the entire facility be kept scrupulously clean. All crevices and holes in floors and walls should be sealed with caulking compound to facilitate cleaning and prevent insects from entering buildings. Galvanized hardware cloth or sheet steel can be fastened to exterior openings such as vents, or around pipes to discourage rodent entry. Some structural conditions can encourage insect and rodent populations: false ceilings, cracks under door and window frames, screens with holes or improper fit, and enclosed areas under cabinets and stairs. Equipment placed too close to walls can hamper cleaning and provide a place for insects and rodents to hide.

Wire mesh and metal screens placed at the base of foundations can help to prevent entry by rats, skunks and other small animals. Where drain pipes enter the building, metal collars around the pipes prevent animals from entering.

Flies and rodents are a frequent problem in feedlots and slaughter houses. Large numbers of flies breed in manure, and rats flourish on feed that is intended to fatten cattle.

Mosquitos lay their eggs in standing water. Even small quantities of water, such as in empty tin cans or discarded tires, provide adequate breeding areas.



Mosquitos can find breeding sites around many industrial areas, especially cooling towers, settling basins, and waste water discharged from industrial processes. If breeding sites cannot be eliminated by filling or draining, they may need to be treated with chemical larvicides.

Several other types of animals can also create sanitation problems: raccoons, skunks, opossums, squirrels, rats, and mice. Some of these animals create problems by their presence alone. Careful study can determine structural entry points used by these animals, and entry points can be blocked. Animals such as rats and mice are sometimes more difficult to eliminate. Some rats, for instance, travel almost exclusively above ground level. These roof rats easily walk on electrical power lines from building to building and can enter through holes no larger than the size of a quarter (\$0.25). Other rats are ground dwellers; however, they, too, can enter through extremely small openings. Dockside grain storage facilities, food storage warehouses, and animal and plant processing facilities are ideal habitats (living places) for various rodent pests.

The most effective way to control and eliminate rodent infestations is through proper housekeeping practices and structural modifications. If a colony is already established, an extermination procedure may need to be conducted.

Small scale extermination of rats can be accomplished with traps or anticoagulant baits, but large infestations warrant professional examination. Professional exterminators are better equipped and better trained to handle poisonous chemicals than are nonprofessionals, and are licensed to do so legally. Before extermination takes place, all plant departments and food vendors should be contacted, and necessary preparations should be made to protect food from contact with harmful chemicals.

Extermination is only the final step in the elimination of pest problems. To prevent recurrence of pest infestation, all of the following approaches should be considered:

- Isolate or eliminate the habitat of the pests. Determine where the pest lives and clean up that area. If the pest is entering from outside the building or area, determine points of entry and try to eliminate them.



- Isolate or eliminate the food supply. In some manufacturing processes, it may be possible to eliminate the food supply without stopping production. In that case, frequent and careful inspection, good housekeeping, and proper storage techniques should be used.
- Exterminate existing populations.

These ideas and approaches can be used with industrial and commercial facilities as well as in the home. Local county extension agents can also be contacted for assistance and answers to specific questions.

**ACTIVITY 7:**

(Choose the best answer.)

Isolating or eliminating the pest habitat would include all except which one of these actions:

1. Placing wire mesh or metal screens at the base of foundations.
2. Observing where the pest lives and cleaning that area.
3. Sealing holes and crevices in the inhabited area with caulking compound.
4. Placing poisonous substances in the food supply of the pests.

**OBJECTIVE 8:** Summarize the electrical safety, noise abatement, exhaust procedures, and machine guards related to farm industry installed machinery.

Any time machinery is installed and maintained, electrical safety, noise exhaust, and protective guards must be considered. All electrical operated machinery installed in any business establishment should be installed and maintained in accordance with the newly revised (effective date April 16, 1981) OSHA standards, 29 CFR Part 1910, Subpart S. Installations should be made or supervised by a qualified electrician and should comply with all

local codes and regulations. Careful attention to these regulations provides the greatest available measure of safety.

Once equipment is in use, care and common sense on the part of all persons who work with the equipment are necessary to ensure safe operation. Such care will involve regular inspections for obvious dangers: damaged parts, frayed wires, loose connections, detached ground connections, unguarded moving parts, and wet areas near the equipment. It may involve periodic preventive maintenance by a qualified service person. Only persons with the appropriate training or skill should operate any machine.

Where machinery is used, noise can become a problem. Excessive noise is one of the most commonly violated health and safety standards and can cause permanent hearing damage. As of this writing the maximum standard set by OSHA is 90 decibels "A-weighted" (90 decibels averaged for an eight-hour exposure). A person who is exposed to noise of this level for short periods of time is in less danger than one who is exposed all day. Ear protection may be necessary where exposure is fairly constant. (See Figure 9.)

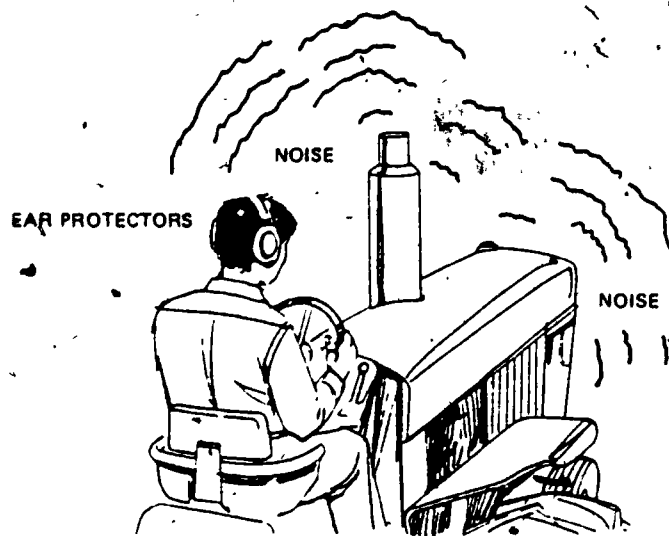

Figure 9. Continuous exposure to excessive noise can cause a hearing loss — use of ear protection is advisable.

Exhaust ventilation systems should always be in place and in use wherever potentially toxic fumes, vapors, or dusts are present in the work environment. Mechanical exhaust ventilation is, in most cases, the first choice

for control of air contaminants that are potential health hazards. A properly designed local exhaust or dilution ventilation system will either remove air contaminants that may be present or lower the concentration of fumes, vapors, dusts, mists, or other contaminants generated in the working environment to reduce or eliminate health or fire hazards.

Local exhaust systems similar to those in Figure 10, should be installed wherever a large volume of air contaminant is generated or where a particularly

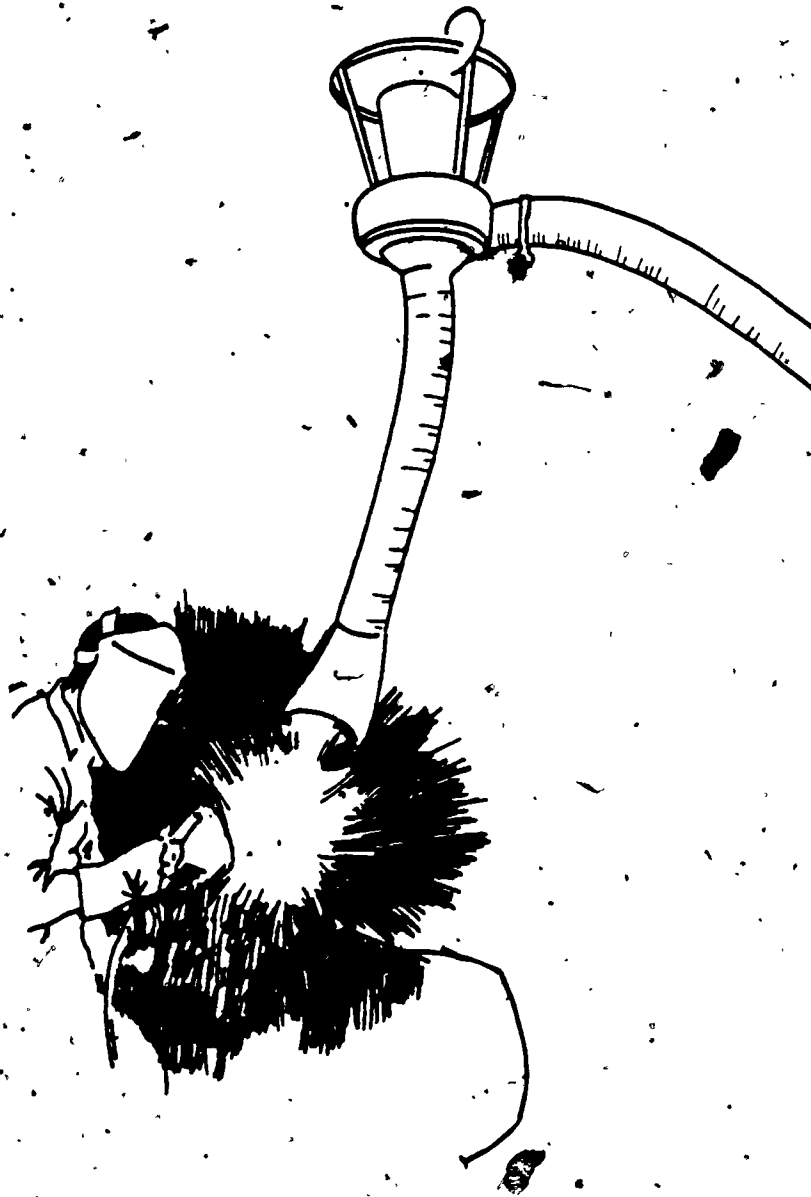
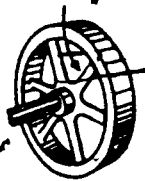

Figure 10. Portable local ventilation.

hazardous substance is used. Some operations that usually require the use of local exhaust ventilation are welding, spray painting, wood working, and processes involving the use of lead, mercury, resins, asbestos, beryllium, flammable liquids, and pesticides.

Machine guarding is an essential safety measure wherever power machines are in use. Any part of a machine that moves presents a hazard. Guarding can eliminate or control this danger.

Those actions or motions classified as the most dangerous are rotating, reciprocating and transverse motions, in-running nip points, cutting actions, and punching, shearing, and bending. Examples of some of these are shown in Figure 11. Even a smooth shaft rotating slowly can grasp clothing or hair, or, upon mere skin contact, force an arm or hand into a dangerous position.



a. Rotating parts create wrapping hazards.

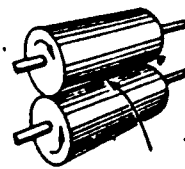
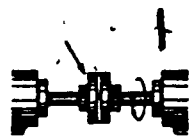

b. Pull in hazard is especially great where materials are fed by hand.

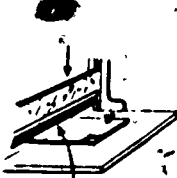

c. Shear points cannot always be mechanically guarded.

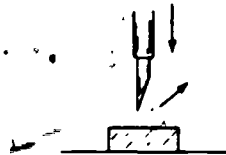
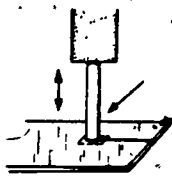

d. Injury can occur when machines that grind or chop throw particles.



Figure 11. Machine hazards.

Couplings, cams, clutches, flywheels, shaft ends, rotating bar stock, and horizontal, or vertical shafting are examples of rotating mechanisms that are hazardous. In many cases, rotating mechanisms located inside a stationary case or shell are revolving cylinders, screw conveyors, agitator blades, and paddles.

The operator should always be aware of the danger that is present when machine parts rotate toward each other or when a part rotates toward a stationary object. These are called in-running nip points. An operator can be severely injured if any part of his body is caught and drawn in at these points. The in-running side of rolling mills and calenders, of rolls used for bending, corrugating, or feeding, and of conveying stock are examples. Other examples are the in-running side of a chain and sprocket, a belt and pulley, a gear rack or a belt conveyor terminal.

The danger of being present at the point that the blade or bit of a machine approaches or comes into contact with the wood, metal, or other material being cut. Band and circular saws, milling machines, planing or shaping machines, turning machines, boring or drilling machines, and grinding machines are typical examples. The cutting action takes place at what is termed the point-of-operation:

Whenever the action or motions of a machine present a hazard, it is essential that the operator and fellow workers be protected by well-constructed, foolproof guards. There are four kinds of guards:

1. Fixed (Figure 12a).
2. Interlocking (Figure 12b).
3. Adjustable (Figure 12c).
4. Self-adjusting (Figure 12d).

The fixed enclosure guard is preferable to all other types because it prevent access to dangerous moving parts by enclosing them completely. The guard admits the stock but will not admit hands because the size of the feed opening is limited. The guard also restrains broken and flying machine parts.

Machine guards must be carefully designed to eliminate hazards, but must not create hazards of their own. They must be in accordance with recognized standards of construction and performance and should not interfere with production.

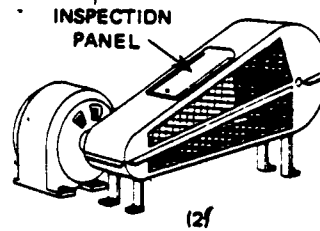
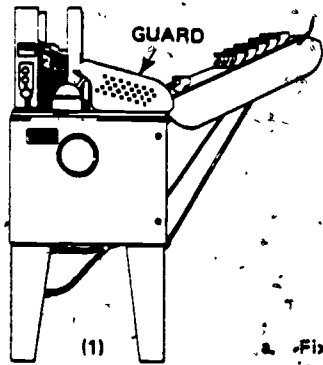

a. Fixed guards on (1) egg carton folding machine and (2) belt and pulley apparatus.

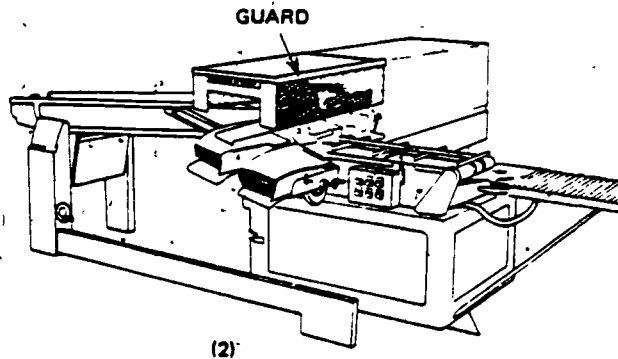
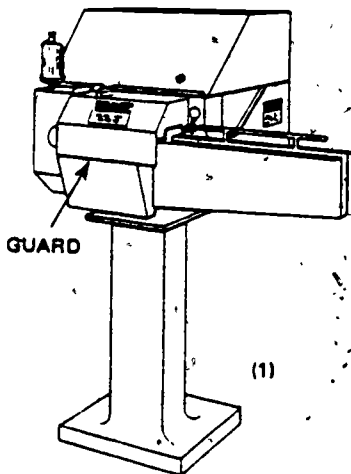

b. Interlocking guards on (1) corn cutter and (2) automatic bread bagging machine.

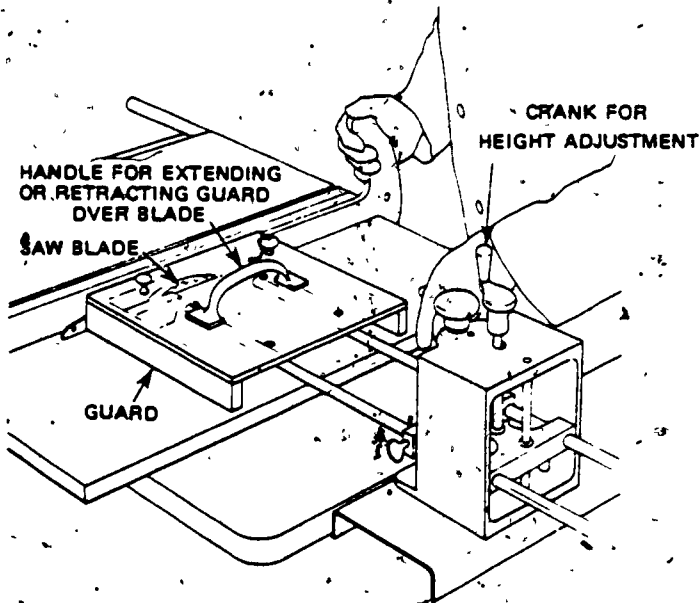

c. Adjustable guard on table saw.

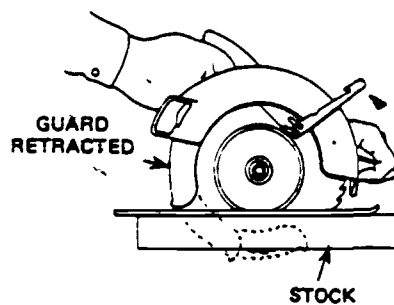

d. Self-adjusting guard on circular saw.

Figure 12. Machine guards.

**ACTIVITY 8:**

1. Name three hazards associated with moving machinery.
  - a. \_\_\_\_\_
  - b. \_\_\_\_\_
  - c. \_\_\_\_\_
2. What kind of substance is used in agribusiness that might require installation of a mechanical exhaust ventilation system? \_\_\_\_\_

**OBJECTIVE 9:** Discuss the workplace use of fire extinguishers, automatic sprinklers, and alarm systems for fire protection.





Fire is an ever-present danger, for agribusinesses and the home. Fire extinguishers, automatic sprinklers, and alarm systems are precautions that could be used in most situations.

The need for properly selected, located, and serviced fire extinguishers in all work locations cannot be over-emphasized. In Table 2, fire classification and extinguisher descriptions are given. Extinguishers are selected according to the type fire that might occur in a given area.

Extinguishers should be located near potential hazards, but not so close that they could be damaged or engulfed by the fire. Specific regulations regarding placement of extinguishers are found in OSHA General Industry Standards (29 CFR 1910.157). Instructions should be posted on or near fire extinguishers.

For some agribusiness operations automatic sprinkler systems provide excellent protection in areas where flammable materials are stored or used, particularly where the area is likely to be unattended much of the time. When used, such sprinkler systems must conform to NFPA standards and OSHA requirements. The system should be installed and maintained by competent technicians. Among the requirements for adequate installation are these:

TABLE 2. EXTINGUISHER CLASSIFICATION.

<p style="text-align: center;"><b>CLASS A</b></p> <p style="text-align: center;"> Ordinary combustible materials (wood, paper, etc.) REQUIRE cooling - quenching.</p>	<p style="text-align: center;"><b>CLASS B</b></p> <p style="text-align: center;"> Flammable liquids, greases, (gasoline, oils, paints, etc.) REQUIRE smothering.</p>
<p style="text-align: center;"><b>CLASS C</b></p> <p style="text-align: center;"> Electrical equipment (motors, switches, etc.) REQUIRES a non-conducting agent capable of extinguishing a fire in materials that may be present.</p>	<p style="text-align: center;"><b>CLASS D</b></p> <p style="text-align: center;"> Combustible metals (magnesium, titanium, sodium, potassium, etc.) REQUIRE special extinguishing agents or techniques.</p>

- Each system must have a least one automatic water supply of adequate pressure and dependability.
- One or more fire department connections must be provided.
- Adequate distance between the tops of stored goods and the sprinklers must be maintained.
- An audible alarm must be provided with the system.

Separate alarm systems furnish the greatest measure of safety for persons working in or near an area where fire might break out. They allow evacuation of the building and reporting of the fire at the earliest time to reduce loss of life and property. The fire alarm system, once installed, must be under the supervision of a qualified individual. The system must be tested and inspected weekly. Evacuation routes and procedures must be carefully established and practice sessions provided for all affected employees on a regular basis. Generally, a fire alarm includes the following:



- Detection system: The fire alarm system must include detection devices — each designed for the area it is to protect. Typical detection devices are smoke detectors, flame detectors, and heat detectors. The decision regarding the type of detector to use should be made in consultation with the local fire department.
- Warning system: The warning system should include warning bells or buzzers and wall-mounted fire alarm activators at strategic locations throughout the facility. The warning system should be connected to the local fire department.

In the event of a fire in a home or public building, including the workplace, the sequence of emergency actions is the same:

FIRST, alert people to leave the building.

NEXT, see that the fire is reported to the fire department so that help can be secured.

THEN, if the fire is small and trained personnel are available, attempt to fight it with available equipment, if that can be done without substantial danger to life and safety.

**ACTIVITY 9:**

1. Indicate which class fire extinguisher would be used to fight each of these fires:
  - a. Smoldering sawdust \_\_\_\_\_
  - b. Overheated electric motor \_\_\_\_\_
  - c. Flaming petroleum-based pesticide \_\_\_\_\_
  - d. Grain storage room fire \_\_\_\_\_
  - e. Smoldering rags \_\_\_\_\_
2. Two main parts of a fire alarm system are the \_\_\_\_\_ system and the \_\_\_\_\_ system.
3. In the event of a fire in a place of business, there are three actions that must be taken very rapidly and in order. They are:
  - a. First \_\_\_\_\_  
\_\_\_\_\_
  - b. Second \_\_\_\_\_  
\_\_\_\_\_
  - c. Third \_\_\_\_\_  
\_\_\_\_\_

**OBJECTIVE 10:** Describe in a few sentences the proper storage, labeling, safe use, and security for hazardous materials.

All materials and chemicals should be stored safely and securely. Tools, parts, and accessories should be stored neatly and arranged in an orderly and accessible way in the places provided, regardless of the specific storage method. Those items used most frequently should be stored within easy reach on the lower shelves. Storage areas must be clean, orderly, ventilated, and well lighted. Containers, bins, shelves, and drawers that contain caustics, acids, solvents, and bundles of materials should never be stored on the tops of lockers or cabinets, because there is always the danger of objects falling from these places. Generally, vertical storage of long pieces of material creates greater hazards than horizontal storage.

Storage rooms should be located adjacent to the work area and close to places where the materials are needed. Supply storage areas should be located in or near the shop, so that there is easy access to materials without having to cross the paths or traffic patterns of others. Safety and ease of storage, delivery of supplies, and the issuing of materials should be considered when planning the location of storage facilities. It is desirable to have an outside door or unloading ramp near the storage room. Storage areas should be arranged and located to reduce traffic and eliminate congestion. Crowded areas are common accident sites.

Tool panels and cabinets should be located away from hazardous machinery. Supplies of flammable liquids should be stored in an area apart from the main building. The storage facility for flammable liquids and other materials should be located so that the sun's rays and other sources of heat do not reach them. Chemicals that may react with one another if spilled should be stored separately in compatible groups. Accurate inventories should be kept of all chemicals with dates noted on all containers. If the chemical has passed its expiration date it should be disposed of immediately. Careful rotation of all chemical stocks should help avoid losses resulting from the disposal of old stock.

A combination of security systems of materials storage is used by most. For safety reasons, some materials, particularly hazardous chemicals, should be in locked storage areas and used only under immediate supervision. Other materials may be stored in accessible areas.

The storage of flammable liquids, such as gasoline, thinners, and other liquids, presents many problems from the standpoint of health, convenience, fire control, fire prevention, and explosions. Storing such materials can be very troublesome and dangerous unless flammable liquid storage areas are carefully planned and provisions are made to safely care for the various types of flammable materials.

Flammable and combustible liquids are categorized by their ease of ignition. Flammable liquids vaporize (turn into a gas) readily, and it is these easily ignited vapors that make them hazardous. If the vapors are trapped in a container when ignited, they may also create an explosion that can cause the fire to spread. Examples of flammables are gasoline, acetone, lacquer, and thinner. Examples of combustibles are kerosene, fuel oil, and Stoddard solvent. Connections on all drums and pipes containing flammable and combustible liquids must be vapor- and liquid-tight.

When flammable liquids are transferred from one container to another (for example, from one bulk container to another), the containers must be effectively bonded and grounded (Figure 13). This practice prevents the

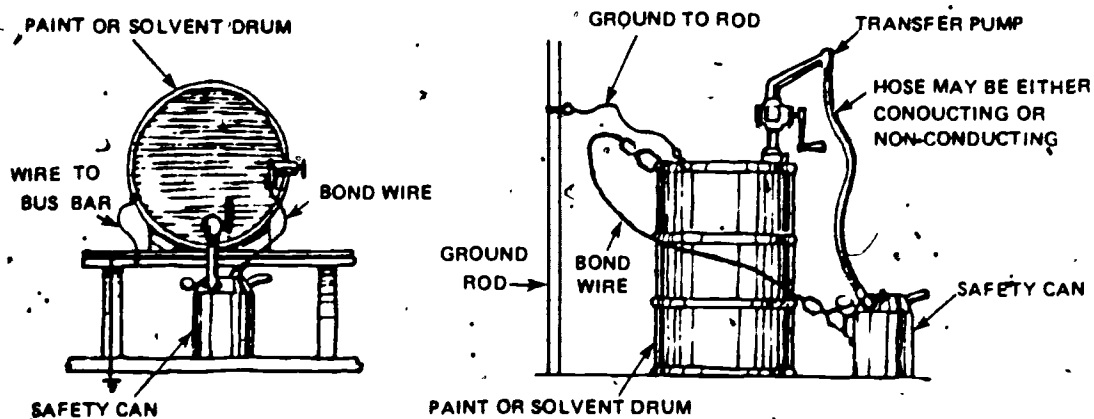

Figure 13. Drums grounded and bonded to receiving container.

accumulation of static charge caused by the transfer process which can result in an electrical discharge (e.g., sparks).

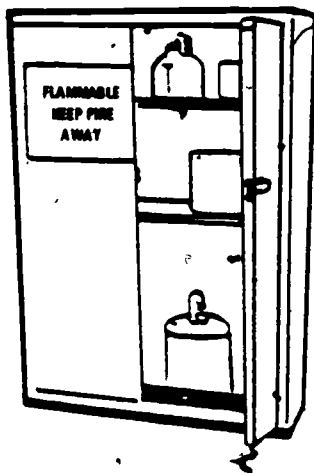

Figure 14. Storage cabinets must be distinctly marked "FLAMMABLE - KEEP FIRE AWAY."

All spills of flammable or combustible liquids must be cleaned up promptly. Supplies of flammable and combustible liquids must be stored in approved fire-resistant safety containers that can be purchased from an industrial supply house. All flammable liquids must be kept in closed containers when not in use. Combustible waste materials, such as oily shop rags or paint rags, must be stored in covered metal containers and be disposed of daily.

Storage cabinets (Figure 14) must be distinctly marked "FLAMMABLE - KEEP AWAY." In order to be safe these storage cabinets should meet National Fire Protection Association test requirements. Cabinets constructed in the following manner will meet these requirements:

- Metal cabinets must be constructed of at least No. 18 gage sheet iron, double-walled with tight joints and a 1-1/2 inch air space between. Doors must have three-point locks with a sill raised at least two inches above the cabinet door.
- Wooden cabinets must be constructed of at least one-inch plywood with rabbeted joints fastened in two directions with flathead screws.

It is essential that all storage areas be kept clean and free of clutter at all times, and that NO SMOKING rules be consistently enforced.

Packages containing potentially dangerous materials should be clearly labeled as to the hazard that each poses, and such materials should be kept in the original containers. Lids and caps should be kept sealed while stored. Care should be taken during the disposal of waste flammables.

**ACTIVITY 10:**

When flammable liquids are transferred from one container to another, they must be effectively \_\_\_\_\_ and \_\_\_\_\_:

**OBJECTIVE 11:** Describe the safety guidelines for housekeeping, walking and working surfaces, exits and disaster plans.

Every person who uses or works in a place shares the responsibility for the safety of all that work there. This responsibility includes the areas of housekeeping, walking and working surfaces, exits, and disaster plans. Good housekeeping contributes to a safer workplace by reducing the potential for fire, and for accidents caused by slips, trips, and falls. Falls are one of the chief contributors to injury; safe housekeeping can reduce their potential. Accumulations of waste and scrap and spills of slippery material (oil) must be cleaned up promptly or at least covered with compounds to absorb the material for clean up purposes. Accumulations of ice during winter months should also be removed in areas where workers frequently move about. Good housekeeping contributes to increased safety during materials handling and storage. An orderly workplace with unobstructed aisles and passageways can significantly reduce work time, frustration, and injuries.

Aisles should provide easy access to exits and fire control equipment. They should be straight and clear of obstructions. A clear space should be maintained around fire protection equipment and the location of such equipment should be well marked. Floors, stairways, and loading areas must be kept clear of slipping and tripping hazards, such as oil spills or splintered or damaged floors.

Safety demands that all personnel be prepared for emergencies that might arise, such as fires or pesticide spills. It is important that a particular person be designated to notify the appropriate authorities of the dangerous situation and that this notification take place while the evacuation procedure begins. To assure proper notification, a list of telephone numbers for the local fire departments and other emergency services should be posted in

several prominent locations throughout the area. Also, floor plans for designated areas should be posted showing locations of fire alarm activators, fire extinguishers, and exits, and if a fire brigade system is used, a group of employees in each area and on each shift should be trained in the correct use of available fire fighting equipment.

A plan for orderly evacuation should include the following:

- An evacuation signal.
- A well-planned evacuation route for all areas of the facility.
- Designation of an assembly area for persons well away from the building.
- An accounting procedure for all persons after evacuation (a daily list of those absent should be made to simplify accounting).
- A search of the building to assure complete evacuation. Floor or area "wardens" should be designated to cover all areas.

The final responsibility for safety in the agribusiness workplace rests with owners, supervisors, and workers. An attitude that "safety is everybody's business," coupled with a genuine concern for the well being of all persons, can provide a substantial contribution toward the achievement of job safety. Alert and informed people with these attitudes can make every job location a better place to work.

**ACTIVITY 11:**

1. Describe four ways in which aisles and walkways can be kept safe.
  - a. \_\_\_\_\_
  - b. \_\_\_\_\_
  - c. \_\_\_\_\_
  - d. \_\_\_\_\_
2. Name at least three things that need to be done to be prepared for an emergency.
  - a. \_\_\_\_\_
  - b. \_\_\_\_\_
  - c. \_\_\_\_\_

3. Five parts are suggested for an orderly evacuation plan. They are:

- a. \_\_\_\_\_
- b. \_\_\_\_\_
- c. \_\_\_\_\_
- d. \_\_\_\_\_
- e. \_\_\_\_\_

4. Who is responsible for the safety of the workplace?

\_\_\_\_\_

## REFERENCES

Accident Prevention Manual For Training Programs. Strong, Merle E., editor. American Technical Society, 1975.

Calvin, Thomas S. and Turner, Howard J. Applying Pesticides. Athens, GA: American Association for Vocational Instructional Materials, Engineering Center, 1980.

National Safety Council. Accident Facts. 1979 edition.

"Principles of Pesticides Use, Handling and Application." Environmental Protection Agency. Washington, DC: 1980.

U.S. Department of Labor. "Concepts and Techniques of Machine Safeguarding," No. 3067. 1980.

United States Department of Labor, Office of Information. "News," No. 80-726 and 80-727. November 20, 1980.

## ANSWERS TO ACTIVITIES

### ACTIVITY 1

The term "agribusiness" is a combination of agriculture and business. Modern farming requires a vast network of businesses to provide supplies, services, and equipment. All these related businesses including the products processing constitute "agribusiness."

#### ACTIVITY 2.

Agribusiness safety standards are needed to help prevent the pain and suffering as well as the economic loss caused by accidents in the work place.

#### ACTIVITY 3

1. a. Overloaded circuits.  
b. Improperly grounded machines.  
c. Damaged electric cords and plugs.  
d. Wet areas around machines.  
e. Uncovered outlets and switches.
2. "Third prong" of plug and separate ground wire or strap.
3. Can. ( $300 \text{ W}/240 \text{ V} = 1.25 \text{ amp}$ ;  $3600 \text{ W}/240 \text{ V} = 15 \text{ amp}$ ; 7.5 amp; 1 amp; sum of amps = 24.75 amps - less than 30)

#### ACTIVITY 4

Any three of the following.

1. Accumulated trash and rubbish should be cleaned up.
2. Careless smoking should be prohibited.
3. Dangerous chemicals should be controlled and stored properly.
4. Fires should not be left unattended.

#### ACTIVITY 5

1. Any six of these:

Name, ingredients, weight, danger, treatment of swallowing, inhaling, on skin, in eyes, manufacturer, address of maker, EPA number of maker, EPA number of product, hazards, how to store, how to dispose, how to use, reentry statement, type applicator, crops for which recommended, warranty.

2. Clean, dry, well ventilated.
3. Flush with water for at least 15 minutes.

#### ACTIVITY 6

1. a. Contact with metal fences.  
b. High places.  
c. Near tall poles or trees.
2. Carry the electricity to the ground harmlessly.



ACTIVITY 7

4.

ACTIVITY 8

1. Any three of the following:  
Wrapping; shearing, pulling in, throwing of particles.
2. Pesticides.

ACTIVITY 9

1.
  - a. A
  - b. C
  - c. B
  - d. B
  - e. A
2. Detection; warning.
3.
  - a. Alert people in area to leave.
  - b. See that fire is reported to fire department.
  - c. Use available equipment, if the fire is small, to fight the fire.

ACTIVITY 10

Bonded and grounded.

ACTIVITY 11

1.
  - a. Free of obstructions.
  - b. Clean.
  - c. Straight.
  - d. Easy access to exits and fire equipment.
2.
  - a. Designate person to notify authorities.
  - b. Post floor plans.
  - c. Train employees in use of emergency equipment.
3.
  - a. Signal.
  - b. Route.
  - c. Assembly point.
  - d. Accounting procedure.
  - e. Search team.

4. Everybody who works there — owner, supervisor, workers — is responsible for safety in the workplace.